



QUALITY ASSURANCE

POLICY MANUAL

This Quality Manual is a “**C**ontrolled **D**ocument”. **C**opies for distribution to customers and employees are considered to be “**U**ncontrolled” for personal use. **F**or the most current update, contact Iowa Aluminum’s

Quality Control Department

GENERAL

AMENDMENT CERTIFICATION	1
AMENDMENT PROCEDURE	2
AMENDMENT LOG	3
CONTROL PAGE	4
COMPANY OPERATING PHILOSOPHY	5
QUALITY POLICY STATEMENT	6
TABLE OF CONTENTS	7

AMENDMENT CERTIFICATION

Name of Firm: IOWA ALUMINUM, INC.

Address: 10 - 27th AVENUE EAST
ALBIA, IA 52531
U.S.A.

AMENDMENT CERTIFICATION

AMENDMENT REVISION: _____

I hereby certify that this Quality Assurance Policy Manual has been reviewed and amended as necessary to reflect the current Quality Management System.

Pages affected: ALL

Approved By:

Steve Johnson
QUALITY MANAGER

3/29/07
DATE

Donald J. Wityshyn
GENERAL MANAGER

3/29/07
DATE

IOWA ALUMINUM, INC.

AMENDMENT PROCEDURE

The Quality Assurance Policy Manual is amended to reflect any changes to the Quality Management System at Iowa Aluminum, Inc.

The Quality Manager shall submit the Quality Assurance Policy Manual amendments (affected pages) to the General Manager, accompanied by the completed Quality Assurance Policy Manual Amendment Certification Page and Amendment Log.

Quality Assurance Policy Manual amendments require acknowledgment and acceptance, whereby, the General Manager shall review the changes to the Quality Assurance Policy Manual. If the changes are acceptable, the General Manager shall sign and date the Quality Assurance Policy Manual Amendment Certification Page and Amendment Log and return them to the Quality Manager.

The Quality Assurance Policy Manual shall be up-dated by the Quality Manager and re-issued depending upon the nature and extent of the changes made.

The Quality Manager is responsible for the maintenance of the Quality Assurance Policy Manual as described in this section and for reviewing the Quality Assurance Policy Manual annually.

Accepted amendments to the Quality Assurance Policy Manual are recorded on the Amendment Log.

CONTROL PAGE

THE INFORMATION CONTAINED IN THIS QUALITY POLICY MANUAL IS CONSIDERED TO BE PROPRIETARY TO THE MANAGEMENT OF IOWA ALUMINUM, INC.

THIS POLICY MANUAL SHALL NOT BE COPIED IN ANY PART OR FORM, NOR SHALL IT BE COMMUNICATED FOR USE OF ANY OTHER PARTY.

THE QUALITY MANAGER SHALL MAINTAIN RESPONSIBILITY AND AUTHORITY FOR THE MAINTENANCE, DISTRIBUTION AND RE-CALL OF THIS QUALITY POLICY MANUAL.

THIS COPY OF THE MANUAL MUST BE RETURNED TO THE QUALITY MANAGER WHEN REQUESTED.

THIS QUALITY POLICY MANUAL IS A CONTROLLED DOCUMENT AND IS ASSIGNED A CONTROL NUMBER FOR RECORDING PURPOSES.

THE CONTROL NUMBER OF THIS COPY IS: _____

AND IS ASSIGNED TO:

NAME: _____

TITLE: _____

COMPANY: _____

ADDRESS: _____

DISTRIBUTED ON THIS DATE: _____

IOWA ALUMINUM, INC.

OPERATING PHILOSOPHY

IOWA ALUMINUM, INC. IS COMMITTED TO A QUALITY MANAGEMENT SYSTEM THAT MAKES QUALITY A BASIC BUSINESS PRINCIPLE. THE STRATEGY IS BASED ON CUSTOMER SATISFACTION ACHIEVED BY MEETING OUR INTERNAL AND CUSTOMER REQUIREMENTS.

CONFORMANCE TO OUR CUSTOMER'S REQUIREMENTS AND EXPECTATIONS IS THE RESPONSIBILITY OF ALL EMPLOYEES AT IOWA ALUMINUM.

QUALITY MANAGEMENT SYSTEM PROCEDURE AND WORK INSTRUCTION PRACTICES ARE DEVELOPED, REVIEWED AND REVISED WITH PARTICIPATION OF EMPLOYEES IN A CONTINUOUS IMPROVEMENT EFFORT.

THE IOWA ALUMINUM'S GOAL IS TO CONTINUE MEETING WORLD CLASS STANDARDS FOR THE MUTUAL BENEFIT OF OUR CUSTOMERS AND EMPLOYEES.

IOWA ALUMINUM, INC.

QUALITY POLICY STATEMENT

**CUSTOMER SATISFACTION IS OUR
MOST TREASURED VALUE.**

**A SATISFIED CUSTOMER IS OUR
MOST VALUED TREASURE.**

Donald J. Wityshyn
GENERAL MANAGER
IOWA ALUMINUM, INC.

3/29/07
DATE

TABLE OF CONTENTS

TITLE	PAGE
SECTION 1 – GENERAL	8
1.1 INDEX AND REVISION STATUS	8
1.2 INTRODUCTION	9
1.3 EXCLUSIONS	10
SECTION 2 – TERMINOLOGY	11
2.1 RELATED DOCUMENTS	11
2.2 DEFINITIONS	12
SECTION 3 – ORGANIZATION	13
3.1 ORGANIZATION STRUCTURE	13
3.2 FACILITIES	14

SECTION 1 GENERAL

1.1 INDEX AND REVISION STATUS

QUALITY MANAGEMENT SYSTEM MANUAL	PAGE	REV
4 QUALITY MANAGEMENT SYSTEM	15	
4.1 General Requirements	15	
4.2 Documentation Requirements	17	
5 MANAGEMENT RESPONSIBILITY	18	
5.1 Management Commitment	18	
5.2 Customer Focus	19	
5.3 Quality Policy	20	
5.4 Planning	21	
5.5 Responsibility, Authority and Communication	23	
5.6 Management Review	24	
6 RESOURCE MANAGEMENT	25	
6.1 Provision of Resources	25	
6.2 Human Resources	26	
6.3 Infrastructure	27	
6.4 Work Environment	28	
7 PRODUCT REALIZATION	29	
7.1 Planning of Realization Processes	29	
7.2 Customer-Related Processes	30	
7.3 Design and Development	31	
7.4 Purchasing	32	
7.5 Production and Serve Operations	33	
7.6 Control of Measuring and Monitoring Devices	34	
8 MEASUREMENT, ANALYSIS AND IMPROVEMENT	35	
8.1 Planning	35	
8.2 Monitoring and Measurement	36	
8.3 Control of Nonconformity	38	
8.4 Analysis of Data	39	
8.5 Improvement	40	

1.2 INTRODUCTION

- 1.2.1 Iowa Aluminum, Inc. develops and manufactures large, highly quality, precision aluminum extrusions for the commercial industry.
- 1.2.2 Iowa Aluminum, Inc. operates from one facility, which is located at 10 – 27th Avenue East – Albia, IA 52531
- 1.2.3 This Quality Assurance Policy Manual describes the Quality System implemented at Iowa Aluminum, Inc.
- 1.2.4 The objective of the Quality System is to prevent non-conformances throughout contract performance and provide for prompt detection of non-conformances and for the provision of timely and effective corrective and preventive action.
- 1.2.5 It is Iowa Aluminum's policy to provide full compliance with Quality System requirements throughout all phases of contract performance and thus ensure that only acceptable products are delivered to the customer.
- 1.2.6 The Quality System outlined in this Quality Assurance Policy Manual and supporting procedures and work instructions are designed to provide compliance with the ISO 9001:2000 Quality Management System Standard.

Donald J. Wityshyn
GENERAL MANAGER
IOWA ALUMINUM, INC.

3/29/07
DATE

1.3 EXCLUSIONS

- 1.3.1 The Quality management System described within this Quality Policy Manual establishes the total Iowa Aluminum, Inc. Quality policy. This Quality Policy Manual, as written, addresses the requirements of ISO9001:2000, except for the exclusion indicated, with justification, below.
- 1.3.1.1 Exclusion: ISO9001:2000) Section 7.3, Design and/or Development, including all subsections.
- 1.3.1.2 Justification: Iowa Aluminum, Inc. does not design, nor develop products. All principle product design and characteristics are specified by our customers, or their specific customers and consultants. Our AutoCAD Engineering activities are limited to developing methods and means of tooling and production requirements and also inspection of characteristics.
- 1.3.2 This Quality policy manual also serves to direct users from the policy statements to the procedures required to support and implement the policy.

SECTION 2 TERMINOLOGY

2.1 RELATED DOCUMENTS

2.1.1 Documents related to this Quality Policy Manual include:

- 2.1.1.1 All procedures with the prefix “QAP and other procedures referenced within the pages of this Quality Policy Manual.**
- 2.1.1.2 Any work instruction that directly or indirectly supports the Quality Policy Manual and procedures or has an impact on product or process.**
- 2.1.1.3 Any form used in conjunction with the Quality Policy Manual, procedures and work instructions described above.**

2.3 DEFINITIONS

- 2.3.1 Quality Policy - The company's requirements on issues affecting quality and support of ISO9001:2000 requirements.
- 2.3.2 Quality Procedure - Directions for supporting and implementing the Quality Policy. This document provides for what should be done to support the Quality Policy.
- 2.3.3 Work Instructions - Detailed descriptions of work to be done in producing and inspecting acceptable product. This document provides for instructions on how to do what is required and supports quality procedures. Work instructions are also used for related tasks such as calibration and preventive maintenance.
- 2.3.4 Quality Management System - A structured approach to reduce variation and to minimize or eliminate defects. The system also prevents occurring defects from reaching the customer.

SECTION 3 ORGANIZATION

3.1 ORGANIZATION STRUCTURE

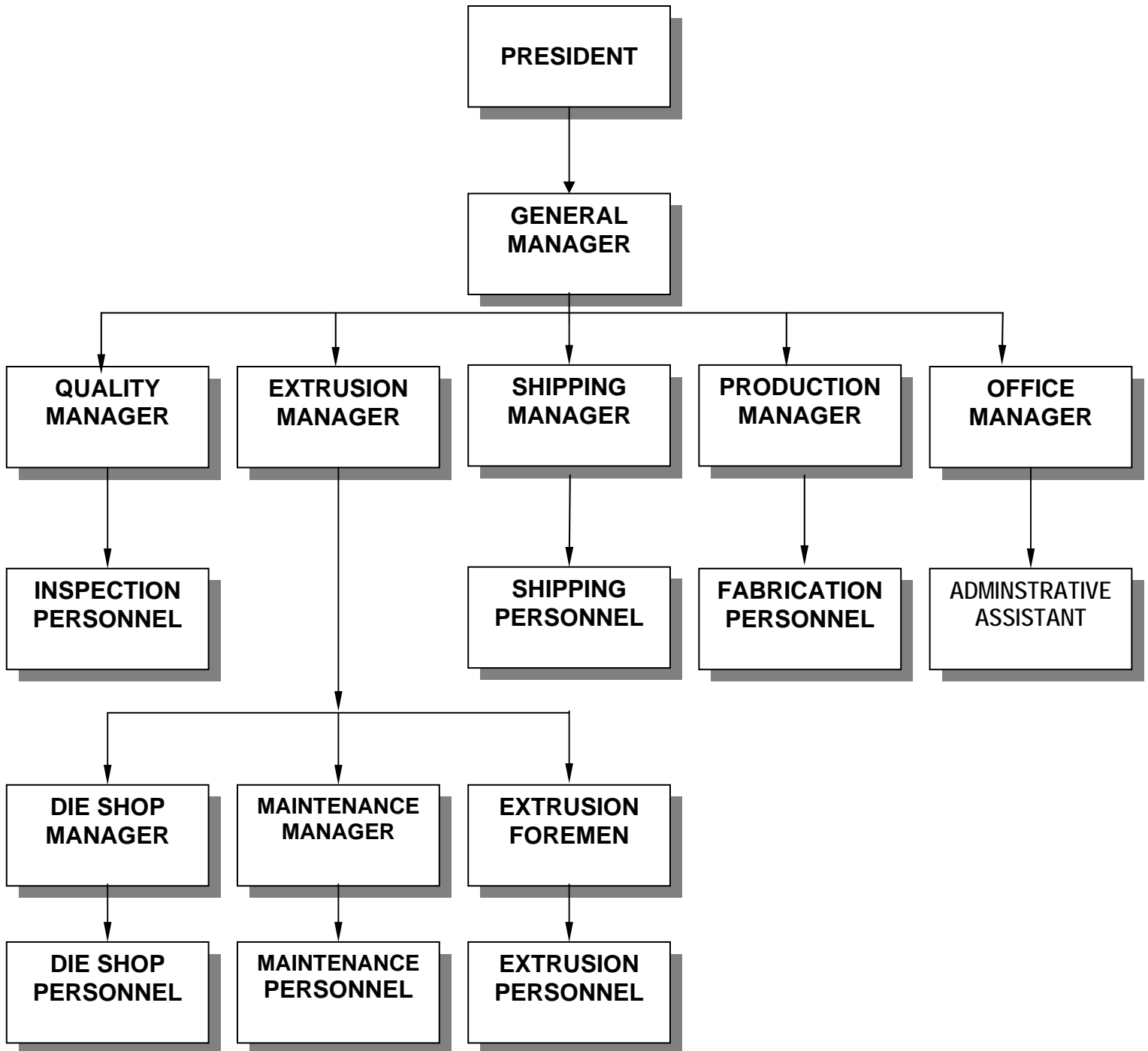

4.0 FACILITIES

- 1.1 Iowa Aluminum, Inc. operates from one facility encompassing about 80,000 sq. ft.
- 1.2 The facility houses administration and sales offices, AutoCAD engineering, quality testing laboratory, aluminum extrusion, heat treating and packaging operations, secondary operations such as precision saw cutting, hole punching, die shop and maintenance areas, raw material and finished goods storage areas.

1.3 Building Layout:

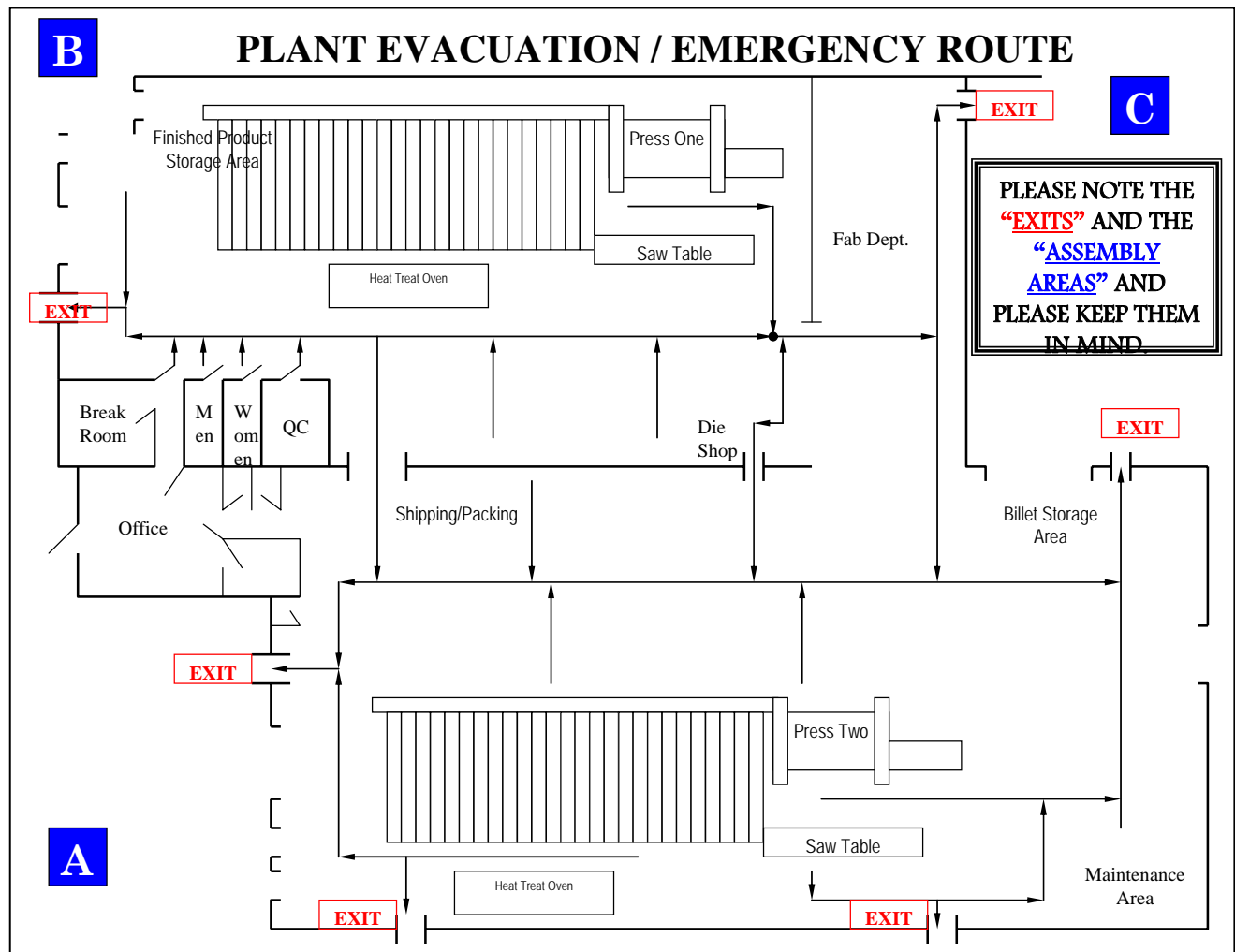

4 QUALITY MANAGEMENT SYSTEM

4.1 General Requirements

Purpose

To establish, document, implement, maintain and continually improve a Quality Management System in accordance with ISO 9001-2000 at Iowa Aluminum.

Reference

Q.A.P. No. 4.1.1 – Quality Management System

Description

- 4.1.1 Iowa Aluminum Inc. has established and documented a Quality Management System in compliance with ISO 9001-2000 Quality System Standard.**
- 4.1.2 The Quality Management System is administered and maintained through written policy, procedures and work instructions and its effectiveness will be continually improved to achieve compliance with ISO9001:2000.**
- 4.1.3 The Process Interaction Map shows the order and interaction of Iowa Aluminum's Quality Management System general processes.**
- 4.1.4 The Quality Management System Procedures describe the methods of compliance to the system elements of ISO 9001:2000. The range and detail of procedures depend upon the complexity of the work, methods used and the skills and training needed by personnel involved in carrying out the activities.**
- 4.1.5 Process Flow and Quality Plans that include Control Plans are established by cross-functional teams prior to production.**
- 4.1.6 Written work and inspection instructions are provided to personnel to describe the methods of performing a given work assignment and for effective control of processes.**
- 4.1.7 Quality Records are generated and audited through the implementation of the Quality Management System to provide objective evidence of compliance and to measure the effectiveness of the system.**
- 4.1.8 The Quality Management System provides an effective and efficient system for assuring product quality in all phases of the operation and for ensuring continuous quality improvement.**

Iowa Aluminum, Inc. – Albia, IA

PROCESS INTERACTION MAP

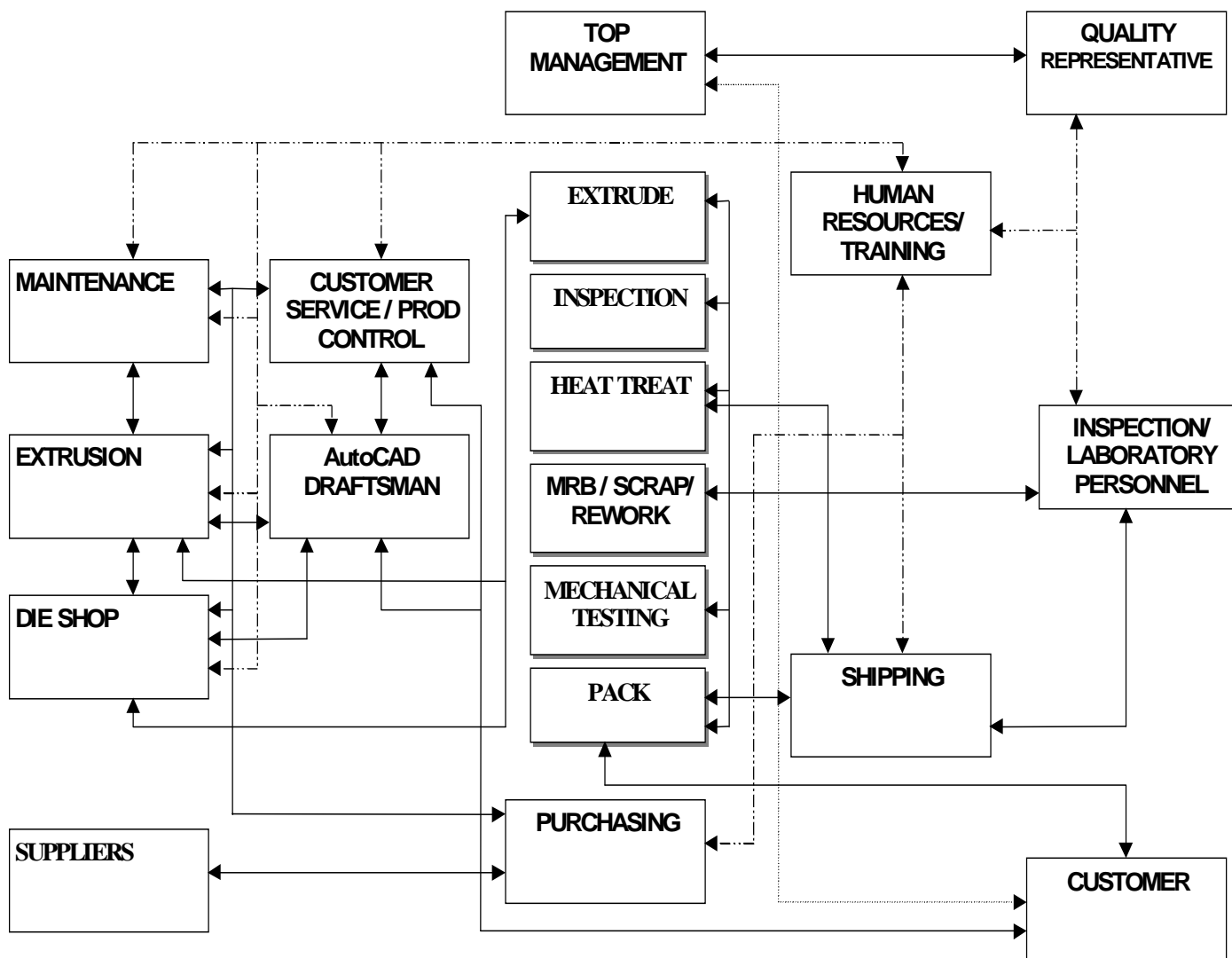

OP4.1.0-1F1 4/5/2007

4 QUALITY MANAGEMENT SYSTEM

4.2 Documentation Requirements

Purpose

To describe the procedures in place for the control, maintenance and distribution of Quality Management System documentation and data at Iowa Aluminum.

Reference

QAP4.2.1-1– Document Data Control and Maintenance
QAP4.2.2-1– Quality Policy Manual
QAP4.2.3-1– Document Data Control
QAP4.2.4-1– Control of Records

Description

- 4.2.1 Documents and data shall be reviewed for adequacy by the Quality Manager and approved by the General Manager prior to issue.
- 4.2.2 Procedures are established to control, maintain and distribute all documentation and data classified as being essential to the effective functioning of the Quality Management System, including documents of external origin.
- 4.2.3 Document changes shall be subject to review and approval by the same authorities that performed the original review and approval, or by those who have access to pertinent information upon which to base their review and approval. Where practicable, the nature of the changes is indicated.
- 4.2.4 Complete and current documentation is made available at workstations.
- 4.2.5 Invalid or obsolete documents are removed from points of issue and use and Obsolete documents that are retained for legal, or reference purposes are properly identified.
- 4.2.6 The Quality Management System includes:
 - a. Documented statement of a Quality Policy and Quality Objectives.
 - b. Quality Manual.
 - c. Documented procedures required by ISO 9001:2000.
 - d. Documents needed by Iowa Aluminum to ensure the effective planning, operation and control of processes.
 - e. Records required by ISO 9001:2000.

5 MANAGEMENT RESPONSIBILITY

5.1 Management Commitment

Purpose

To provide evidence of commitment to the development and improvement of the Quality Management System at Iowa Aluminum.

Reference

QAP5.1.0-1– Management Commitment

Description

- 5.1.1 Iowa Aluminum, Inc. has stated and documented their commitment to quality and their support of the Quality Management System.**
- 5.1.2 Management's Quality Policy Statement is posted and communicated throughout the organization to all personnel.**
- 5.1.3 The responsibility, authority and interrelation of personnel who manage, perform and verify work affecting quality are documented in procedures and associated organization charts are posted.**
- 5.1.4 The Quality Manager reports to the General Manager and possesses the freedom and authority to effectively manage the Quality Management System.**
- 5.1.5 Management reviews in-house verification requirements, ensuring that the necessary resources are available, including the qualification and training of personnel assigned to verification activities.**
- 5.1.6 Although all personnel are responsible for quality as related to their individual work assignments, management has provided for a Quality Manager and Inspection Personnel who carry out verification activities independently of those having direct responsibility for manufacturing.**
- 5.1.7 Management reviews the effectiveness of the Quality Management System on an annual basis and records are maintained.**
- 5.1.8 Key overall trends in quality, operational performance and customer satisfaction are documented, reviewed and compared to objectives.**

5 MANAGEMENT RESPONSIBILITY

5.2 Customer Focus

Purpose

To ensure that the customer needs and expectations are determined, converted into requirements and fulfilled to achieve Customer Satisfaction at Iowa Aluminum.

Reference

QAP7.2.1-1 – Contract Review

Description

- 5.2.1 A system is established to provide for reviewing customer needs and requirements prior to accepting a purchase order.**
- 5.2.2 Customer requests for quotations are reviewed by the General Manager, Plant Manager and Quality Manager to determine customer requirements and expectations.**
- 5.2.3 Discussions are held to determine any problem areas, concerning the product or process, that may arise and what alternative measures can be made to resolve these problems.**
- 5.2.4 Any important information that would enhance the quality of product or process is given to the customer as improvement to the requirements.**
- 5.2.5 Drawings, specifications and other pertinent documents are reviewed to determine if the requirements can be met.**
- 5.2.6 Changes to the drawings, specifications and other pertinent documents are noted and forwarded to the customer for review.**
- 5.2.7 Availability of product and expected delivery are reviewed to determine if there is adequate raw material to produce the product and whether delivery schedules can be met.**
- 5.2.8 Any other pertinent information that may be of importance to the improvement of the product is forwarded to the customer for review.**
- 5.2.9 Senior management optimizes the likelihood of customer satisfaction and by routinely assessing customer satisfaction through customer surveys serves that purpose.**

5 MANAGEMENT RESPONSIBILITY

5.3 Quality Policy

Purpose

To ensure that a Quality Policy is established and communicated and understood at appropriate levels of the organization at Iowa Aluminum.

Reference

QAP5.3.0-1 – Quality Policy

Description

- 5.3.1 A system is established to provide for ensuring that a Quality Policy has been established and is communicated to all levels of the organization.**
- 5.3.2 The company's Quality Policy Statement can be reviewed in its entirety on page 6 of this manual.**
- 5.3.3 The General Manager will ensure that the Quality Policy represents the company's quality intentions, objectives and company goals.**
- 5.3.4 The General Manager will ensure that all levels of the organization understand the Quality Policy Statement and that it can be expressed in one's own words.**
- 5.3.5 The General Manager will ensure that the Quality Policy is communicated to all levels of the organization and personnel at all levels of the organization are expected to fulfill the requirements of this policy in all of their work related efforts and decisions.**
- 5.3.6 The General Manager will ensure that the Quality Policy is reviewed on an annual basis.**

5 MANAGEMENT RESPONSIBILITY

5.4 Planning

Purpose

To ensure that the resources needed to achieve the quality objectives are identified and planned at Iowa Aluminum.

Reference

QAP5.4.1-1 – Quality Objectives

QAP5.4.2-1 – Quality Plans

Description

- 5.4.1 A system has been established to ensure that quality objectives have been established at relevant functions and levels of the organization to meet the needs and expectations of customers.
- 5.4.2 Quality objectives have been established to meet the specific requirements and performance of the product and performance of the Quality Management System processes.
- 5.4.3 Quality objectives are measurable, with respect to lessons learned and continuous improvement and are consistent with the Quality Policy.
- 5.4.4 The following measurable quality objectives have been formulated by the highest level of management:
- To maintain acceptable profitability by providing our customers with an acceptable quality part produced in the most efficient manner possible.
 - To provide for product quality by management's full support and necessary resources for continual implementation of the Quality Management System.
 - To maintain acceptable quality productivity through management participation at all levels in Quality Assurance activities in daily functions.
 - Provide for customer satisfaction of product by ensuring that no product will be shipped until it's quality and conformance has met customer specifications.
 - Provide customer feedback through the use and posting of Customer Surveys, Customer Complaints, Delivery Performance, Graphs, Charts and Newsletters.
 - Provide for assessing the effectiveness of the Quality Management System by conducting Management Reviews, Reviewing Corrective Actions and Implementing Preventive Action Plans to eliminate recurrence of discrepancies.
 - Provide for continual improvement of the Quality Management System by directing internal efforts towards increased efficiency and quality improvements.
 - To provide for quality and customer awareness through the use of drawings, work instructions, documented training plans, on-the-job and formal training practices and training records.

5 MANAGEMENT RESPONSIBILITY (Continued)

5.4 Planning (Continued)

- 5.4.4.1 To provide for customer service through ongoing technical support, quick reaction to resolve discrepancies and timely visits to the customer's facility concerning follow-up activities.**
- 5.4.5 The above quality objectives are submitted to managers at subsequent levels, which are converted into objectives at their level and then submitted to a lower level until the product specific objectives have been created.**
- 5.4.6 Quality planning at Iowa Aluminum ensures that change is conducted in a controlled manner and that the integrity of the Quality Management System is maintained during this change.**

5 MANAGEMENT RESPONSIBILITY

5.5 Responsibility, Authority and Communication

Purpose

To ensure that the functions and their interrelations, including responsibilities and authorities, are communicated in order to facilitate effective quality management at Iowa Aluminum.

Reference

QAP5.5.1-1 – Responsibility and Authority
QAP5.5.2-1 – Management Representative
QAP5.5.3-1 – Internal Communication

Description

- 5.5.1 Iowa Aluminum has established a procedure for identifying the responsibilities of key functions of the organization.**
- 5.5.2 All key personnel have been given the authority and responsibilities to enable them to assist in the achievement of the quality objectives.**
- 5.5.3 This assignment of authority and responsibility helps Iowa Aluminum to establish involvement and commitment of personnel throughout the organization.**
- 5.5.4 The General Manager has appointed the Quality Manager as Management Representative who has the responsibility of ensuring that the performance and any needs for improvement of the Quality Management System is reported to top management and promoting awareness of customer requirements throughout the organization.**
- 5.5.5 All responsibilities and authority of key personnel have been communicated and documented to ensure that the organization will have adequate representation at all levels of the organization to effectively operate the company and it's Quality Management System.**
- 5.5.6 Responsibilities and authority of key personnel are reviewed periodically for strengths and weaknesses to assure effective representation of the Quality Management System.**
- 5.5.7 Communication means are established in the form of meetings, notices and plant newsletters to provide for the communication of quality requirements, objectives and accomplishments.**

5 MANAGEMENT RESPONSIBILITY

5.6 Management Review

Purpose

To ensure that the resources needed to achieve the quality objectives are identified and planned at IOWA Aluminum.

Reference

QAP5.6.1-1 – Management Review

Description

- 5.6.1 The Quality management System is periodically reviewed by management at planned intervals to ensure it's continuing suitability, adequacy and effectiveness.**
- 5.6.2 A Management Review of the Management Quality System is conducted annually by members of management to evaluate its effectiveness and efficiency and to verify that the Quality Policy and Objectives are being met.**
- 5.6.3 Management Review also analyzes the current activities that may require change and consider opportunities for improvement of the Quality Management System.**
- 5.6.4 Inputs to the Management Review shall include Audits of the Quality Management System, customer satisfaction, performance of processes and products, status of corrective/preventive actions, status of action items from previous reviews and any changes in original assumptions concerning new technologies, quality concepts, etc. Additional inputs will be considered, as they become necessary to the review.**
- 5.6.5 Outputs to the Management Review shall focus on added value for customers, improved performance of processes and products, suitability of organizational structure and resources, ability to introduce new product on time in the market, managing risks, compliance with relevant statutory and regulatory requirements and planning for the future.**
- 5.6.6 Results of the Management Reviews shall be recorded and available for review.**

6 RESOURCE MANAGEMENT

6.1 Provision of Resources

Purpose

To ensure that the resources needed to achieve the quality objectives are identified and planned at Iowa Aluminum.

Reference

QAP6.1.0-1 – Provision of Resources

Description

- 6.1.1 Resources essential to the implementation and achievement of the organization's strategies and objectives for the Quality Management System are identified and are available.**
- 6.1.2 Resources include people, suppliers, information, infrastructure, work environment and financial resources necessary to achieve customer satisfaction and meeting customer requirements.**
- 6.1.3 Consideration is given to provision of resources, tangible resources, intangible resources, continual improvement, organizational structures, information management, training, use of natural resources and planning for the future.**

6 RESOURCE MANAGEMENT

6.2 Human Resources

Purpose

To ensure that the resources needed to achieve the quality objectives and to perform the required work are adequately trained and experienced at Iowa Aluminum.

Reference

QAP6.2.1-1 – Quality System Resources

QAP6.2.2-1 – Training

Description

- 6.2.1 Resources essential to the implementation and achievement of the organization's strategies and objectives for the Quality Management System are adequately trained and experienced.**
- 6.2.2 Training of resources is conducted through the use of formal classroom training, on the job training and one-on-one training.**
- 6.2.3 Training plans are implemented for each job classification and personnel are evaluated throughout their training period and beyond.**
- 6.2.4 Job classifications shall be evaluated for competency according to appropriate education, training, skills and experience.**
- 6.2.5 Management shall identify what skills are required for the tasks that affect product quality and provide adequate training to personnel who will be performing those tasks. All training administered shall be evaluated with respect to the effectiveness of the training.**
- 6.2.6 Management shall make every effort to ensure that personnel are made aware of the importance of their tasks through newsletters, customer feedback, awards, personal recognition and other positive means necessary to motivate personnel.**
- 6.2.7 Management shall ensure that all training, education and experienced gained is documented and available for review.**

6 RESOURCE MANAGEMENT

6.3 Infrastructure

Purpose

To ensure that the facility resources needed to achieve conformity of the product and to provide for the foundation of the operation are identified, provided and maintained at Iowa Aluminum.

Reference

QAP6.3.1-1 – Infrastructure

Description

- 6.3.1 Facility resources essential to the infrastructure are identified, provided and maintained to ensure conformity of the product.
- 6.3.2 Management shall provide for adequate facilities to include buildings, workspace, tools and equipment, transportation, hardware, software, communication and other essential supporting services to ensure an environment that will support product conformity.
- 6.3.3 Management shall define infrastructure in terms such as objectives, function, performance, availability, cost, safety, security and renewal and to implement a maintenance approach to ensure that the infrastructure continues to meet operational needs.
- 6.3.4 Management shall evaluate the infrastructure against the needs of the customer and also consider environmental issues such as conservation, pollution, waste and recycling.

6 RESOURCE MANAGEMENT

6.4 Work Environment

Purpose

To identify and manage the human and physical factors of the work environment needed to achieve conformity of product at Iowa Aluminum.

Reference

QAP6.4.1-1 – Work Environment

Description

- 6.4.1 Human and physical factors are identified and managed to ensure support motivation, satisfaction and performance of personnel in their work environment.**
- 6.4.2 Management shall provide for creative work methods, opportunities for greater involvement, safety rules and guidance, adequate safety and protective equipment, ergonomics and special facilities for personnel in the organization.**
- 6.4.3 Management shall evaluate and control physical factors that affect the work environment to include heat, noise, light, hygiene, humidity, cleanliness, vibration, pollution and airflow.**

7 PRODUCT REALIZATION

7.1 Planning of the Product Realization

Purpose

To provide for proper planning to ensure the sequence of processes and sub-process required to achieve the product are operating as an efficient system at Iowa Aluminum.

Reference

QAP7.1.1-1 – Planning of the Product Realization

Description

- 7.1.1 Management shall ensure that planning of the organization's product realization is consistent with the requirements of the other processes of the Quality Management System.
- 7.1.2 When planning the product realization, management shall determine the quality objectives and requirements for the product, the need to establish processes, documents and provide resources specific to the product.
- 7.1.3 Management shall determine and plan for required verification, validation, monitoring, and inspection and test activities specific to the product and criteria for product acceptance.
- 7.1.4 Management shall determine and identify what records to be kept on file to provide evidence that the product has been properly produced and met requirements.

7 PRODUCT REALIZATION

7.2 Customer Related Process

Purpose

To provide for proper planning to define, implement and maintain processes to ensure adequate understanding of the customer's needs and expectations at Iowa Aluminum.

Reference

- QAP7.2.1-1 – Contract Review
- QAP7.2.2-1 – Customer Purchase Orders
- QAP7.2.3-1 – Customer Communication

Description

- 7.2.1 Management shall determine the requirements specified by the customer to include availability of material, delivery and post-delivery activities as well as requirements not stated by the customer, but necessary for intended use, where known.
- 7.2.2 Management shall determine the statutory and regulatory requirements related to the product such as warranties and support.
- 7.2.3 Management shall identify and review the customer requirements together with additional requirements determined by the management prior to the commitment to supply a product to the customer, or acceptance of a contract order.
- 7.2.4 Management shall ensure that the product requirements are defined and where the customer provides no documented statement of requirement, the customer requirements are confirmed before acceptance and that the ability to meet those defined requirements can be accomplished.
- 7.2.5 Management shall ensure that order requirements that are different from those previously expressed are resolved and when a change is made, the relevant documentation is amended and relevant personnel are made aware of the changed requirements.
- 7.2.6 The results of the review and subsequent follow-up actions shall be recorded and maintained as records.
- 7.2.7 Management shall identify and implement arrangements for communication with customers relating to product information, inquiries, contracts and order handling, amendments, customer feedback, including customer complaints.

7 PRODUCT REALIZATION

7.3 Design and Development

Purpose

To provide for proper method of planning, controlling, verifying and validating product design at Iowa Aluminum.

Reference

QAP7.3.0-1 – Design Control
Policy Manual - Section 1.3 - Exclusions

Description

7.3.1 Iowa Aluminum does not perform any design functions at this facility and therefore, is not subject to design and development.

7 PRODUCT REALIZATION

7.4 Purchasing

Purpose

To provide for proper identification and implementation of purchasing processes for selection, evaluation and control of purchased products to ensure they satisfy needs and requirements of Iowa Aluminum and our customers.

Reference

- QAP7.4.1-1 – Purchasing
- QAP7.4.1-2 - Control of Suppliers
- QAP7.4.1-3 – Approval of Suppliers
- QAP7.4.2-1 – Purchase Order Information
- QAP7.4.3-1 – Verifying Purchased Product
- QAP7.4.3-2 – Receiving Inspection

Description

- 7.4.1 Management shall control purchasing processes to ensure that the purchased product, or service conforms to requirements and this control shall be dependent upon the effect of the purchased product on subsequent product realization or the final product.
- 7.4.2 Suppliers shall be selected and evaluated based on their ability to supply product in accordance with Iowa Aluminum's requirements.
- 7.4.3 Management shall establish criteria for the selection, evaluation and re-evaluation of suppliers and the results of the evaluations including any necessary actions shall be maintained as records.
- 7.4.4 Purchase orders shall clearly describe the product to be purchased including the requirements for approval of the product, procedures, processes and equipment, qualification of personnel and Quality Management System requirements.
- 7.4.5 Management shall ensure that specified purchased requirements of the purchase order are reviewed for adequacy prior to them being communicated to the supplier.
- 7.4.6 Management shall establish and implement inspection and any other activity necessary for ensuring that the purchased product meets specified purchase requirements.
- 7.4.7 Management shall specify in the purchasing information any verification arrangements and method of product release where Iowa Aluminum or our customers intend to perform verification at the supplier's premises.

7 PRODUCT REALIZATION

7.5 Product and Service Provision

Purpose

To properly identify requirements in order to ensure compliance with specifications and to satisfy the needs and expectations of our customers at Iowa Aluminum.

Reference

QAP7.5.1-1 – Control of Production Operations

QAP7.5.1-2 – Machinery and Equipment Maintenance

QAP7.5.3-1 – Product Identification and Traceability

QAP7.5.3-2 – Inspection and Test Status

QAP7.5.5-1 – Handling, Storage, Packaging, Preservation and Delivery of Product

Description

- 7.5.1 Management shall plan and carry out production and service provision under controlled conditions including availability of information that describes the products characteristics, availability of work instructions, use of suitable equipment, availability, use and implementation of monitoring and measuring equipment, and the implementation of release, delivery and post –delivery activities.
- 7.5.2 Management shall ensure that any processes where deficiencies may become apparent only after the product is in use or the service has been delivered have been validated. The results of the validation demonstrate the ability of the processes to achieve planned results.
- 7.5.3 Management shall establish, where applicable, arrangements for defining criteria for review and approval of processes, approval of equipment and qualification of personnel, use of specific methods and procedures and the requirements for records.
- 7.5.4 Management shall ensure that the product is identified by suitable means throughout the product realization including the status of the product with respect to inspection requirements and that traceability is uniquely identified, controlled and kept on record for future requirements. Product shall be protected from atmospheric conditions that may harm product preservation.
- 7.5.5 Management shall ensure that customer property is properly identified, verified, protected and safeguarded with care while under the control of, or being used by Iowa Aluminum. Lost, damaged or unsuitable customer property is recorded, reported to the customer and maintained as a record.

7 PRODUCT REALIZATION

7.6 Control of Measuring and Monitoring Devices

Purpose

To ensure that measuring and monitoring devices used for the verification of products and validation of processes are controlled, calibrated and maintained to accepted standards at Iowa Aluminum.

Reference

QAP7.6.0-1 – Control of Inspection, Measuring and Test Equipment

Description

- 7.6.1 Management shall identify the measurements to be made and the measuring and monitoring devices required to assure conformity of product to specified requirements.
- 7.6.2 Measuring and monitoring devices shall be used and controlled to ensure that measurement capability is consistent with the measurement requirements.
- 7.6.3 Where necessary to ensure valid results, measuring and monitoring devices shall be calibrated or verified at specific intervals, or prior to use, against devices traceable to international or national standards. Where no standards exist, the basis used for calibration shall be recorded.
- 7.6.4 Measuring and monitoring devices shall be protected from damage during handling, maintenance and storage and be safeguarded from adjustments that would invalidate the calibration.
- 7.6.5 Measuring and monitoring devices shall be uniquely identified to enable calibration status, adjusted and re-adjusted as necessary, have the results of the calibration recorded as a record and have the validity of previous results re-assessed if they are subsequently found to be out of calibration. Appropriate corrective action shall be administered on any equipment or product found to be affected.
- 7.6.6 Computer software used for measuring and monitoring of specified requirements shall be confirmed prior to the initial use and reconfirmed as necessary to satisfy the intended application.

8 MEASUREMENT, ANALYSIS AND IMPROVEMENT

8.1 Measurement, Analysis and Improvement

Purpose

To provide for the measurement and evaluation of products, the capability of processes, customer satisfaction and other items required by customers to include recording, collecting, analyzing, summarizing and communicating of relevant data needed to monitor and improve performance at Iowa Aluminum.

Reference

QAP8.1.1-1 – Measurement, Analysis and Improvement

Description

- 8.1.1 Management shall identify measurement criteria and objectives that would lead to consideration of appropriate action and not be purely for the accumulation of data. Results should not only show achievement, but consideration should also be given to trends and variation.**
- 8.1.2 Management shall determine the need for the use of statistical techniques for analyzing data, including verifying process operations and product characteristics. Statistical techniques selected for use should be suitable for the application and should be monitored and controlled.**
- 8.1.3 Management shall plan and implement the monitoring, measurement, analysis and improvement processes to demonstrate conformity of the product, ensure conformity of and to continually improve the effectiveness of the Quality Management System.**
- 8.1.4 The measurements employed by management should be reviewed periodically and data should be verified on a continual basis for accuracy and completeness.**

8 MEASUREMENT, ANALYSIS AND IMPROVEMENT

8.2 Monitoring and Measurement

Purpose

To identify the methodologies needed for identification of areas for improvement in the overall efficiency and effectiveness of the Quality Management System at Iowa Aluminum.

Reference

- QAP8.2.1-1 – Customer Satisfaction**
- QAP8.2.2-1 – Internal Audit**
- QAP8.2.3-1 – Process Control**
- QAP8.2.4-1 – Work Instructions**
- QAP8.2.4-2 – Inspection and Testing**

Description

- 8.2.1 Management shall provide information on a continual basis by requesting, measuring and monitoring feedback of customer satisfaction and dissatisfaction, addressing conformance to requirements, meeting needs and expectations of customers as well as price and delivery of product.**
- 8.2.2 Management shall establish and use sources of customer information and specify the methodologies and measures to be used to gather and analyze the data for review, such as customer complaints, direct communication with customers, questionnaires and surveys.**
- 8.2.3 Management shall provide for internal audits at planned intervals to determine whether the Quality Management System conforms to planned arrangements, requirements of ISO 9001-2000, the Quality Management System and is effectively implemented and maintained.**
- 8.2.4 Management shall ensure that audit programs planned take into consideration the status and importance of the processes and areas to be audited, as well as the results of previous audits.**
- 8.2.5 Management shall define the audit criteria, scope, frequency and method used to assess the strengths and weaknesses of the Quality management System. Auditor selection and conduct of the audits shall ensure objectivity and impartiality of the audit process and that auditors do not audit their own work.**
- 8.2.6 Management shall provide documented procedures to define responsibilities and requirements for planning and conducting audits, reporting results and maintaining records.**

8 MEASUREMENT, ANALYSIS AND IMPROVEMENT

8.2 Monitoring and Measurement (Continued)

- 8.2.7 Management shall apply methods for monitoring and where applicable, measurement of the Quality Management System processes necessary to meet customer requirements and to demonstrate the ability of the processes to achieve planned results and to take corrective action when the planned results are not achieved.**
- 8.2.8 Management shall establish and specify the measurement requirements, including acceptance criteria, for product characteristics and to monitor and measure these requirements to verify that the product requirements are met.**
- 8.2.9 Management shall ensure that monitoring and measurement of product characteristics are carried out at appropriate stages of the product realization process in accordance with planned arrangements and that evidence of conformity with acceptance criteria is documented and maintained.**
- 8.2.10 Management shall ensure that all planned arrangements are satisfactorily completed prior to proceeding with the release of product and that records maintained indicate the person(s) authorizing the release.**

8 MEASUREMENT, ANALYSIS AND IMPROVEMENT

8.3 Control of Nonconforming Product

Purpose

To ensure that product, which does not conform to requirements is identified and controlled to prevent unintended use or delivery at Iowa Aluminum.

Reference

QAP8.3.0-1 – Control of Nonconforming Product

Description

- 8.3.1 Management shall ensure that all personnel have the responsibility to report non-conformances at any stage of the process and that prompt attention to non-conformances are administered to initiate prompt corrective action.**
- 8.3.2 Management shall ensure that nonconforming product is properly identified and controlled to prevent unintended use or delivery and that disposition of nonconforming product is dealt with by a formal review of the nonconformance.**
- 8.3.3 After a formal review of the nonconformance, management shall ensure that proper Disposition of nonconforming product is administered, performed and documented. Disposition may be in the form of:**
- a. Action taken to eliminate the detected nonconformance.**
 - b. Authorized use or release of the nonconforming product (when authorized by the customer).**
 - c. Authorized use or release of the product under concession by a relevant authority.**
 - d. Action taken to preclude its original intended use or application.**
- 8.3.4 Management shall ensure that the nature of a nonconformance and any subsequent actions taken, including any concessions, are recorded and maintained as records.**
- 8.3.5 Management shall ensure that nonconforming product corrected shall be subject to re-verification after correction to demonstrate conformity and that nonconforming product detected after delivery or use has started, shall be given appropriate action regarding the consequences of the nonconformance.**

8 MEASUREMENT, ANALYSIS AND IMPROVEMENT

8.4 Analysis of Data

Purpose

To provide for the collection and analysis of appropriate data to demonstrate the suitability and effectiveness of the Quality management System and to evaluate where continual improvements of the effectiveness of the Quality management System can be made at lowa Aluminum.

Reference

QAP8.4.-1 – Analysis of Data

Description

- 8.4.1 Management shall analyze appropriate data by monitoring, measurement and from other relevant sources to assess performance against plans and goals and to identify any areas of improvement.**
- 8.4.2 Management shall ensure that the analysis of this data provides information related to customer satisfaction, suppliers, conformance to product requirements, characteristics and trends of processes and product to include opportunities for preventive action.**

8 MEASUREMENT, ANALYSIS AND IMPROVEMENT

8.5 Improvement

Purpose

To provide for continuous improvement of the effectiveness of the Quality Management System at Iowa Aluminum.

Reference

QAP8.5.1-1 – Continual Improvement
QAP8.5.2-1 – Corrective Action
QAP8.5.3-1 – Preventive Action

Description

- 8.5.1 Management shall establish plans to continually improve the effectiveness of the Quality Management System through the use of a Quality Policy, objectives, audit results, analysis of data, corrective/preventive action and management review.**
- 8.5.2 Management shall establish a process for corrective action taken to eliminate the cause of non-conformances and to prevent recurrence.**
- 8.5.3 Management shall establish a documented procedure to define the requirements for reviewing non-conformances, including customer complaints, determining the cause of nonconformity, evaluating the need for action to ensure that non-conformances do not recur, determining the implementing action needed and recording, reviewing and maintaining the results of corrective action taken.**
- 8.5.4 Management shall establish a documented procedure to eliminate the causes of potential non-conformances in order to prevent recurrence and to define the requirements to prevent recurrence of nonconformity, determining the implementing action needed and recording, reviewing and maintaining the results of preventive action taken.**